

TLF-AA • Removable Face
**Critical Environment Diffusion Products
Laminar Flow Ceiling Diffusers • Aluminum • Perforated Face**

Accessories (Optional) Check if provided.

- HEPA Filter Rack
 Equalization Baffle
 Insulated Plenum (External)
 MRI Compatible Construction

Optional HEPA Filter Rack:

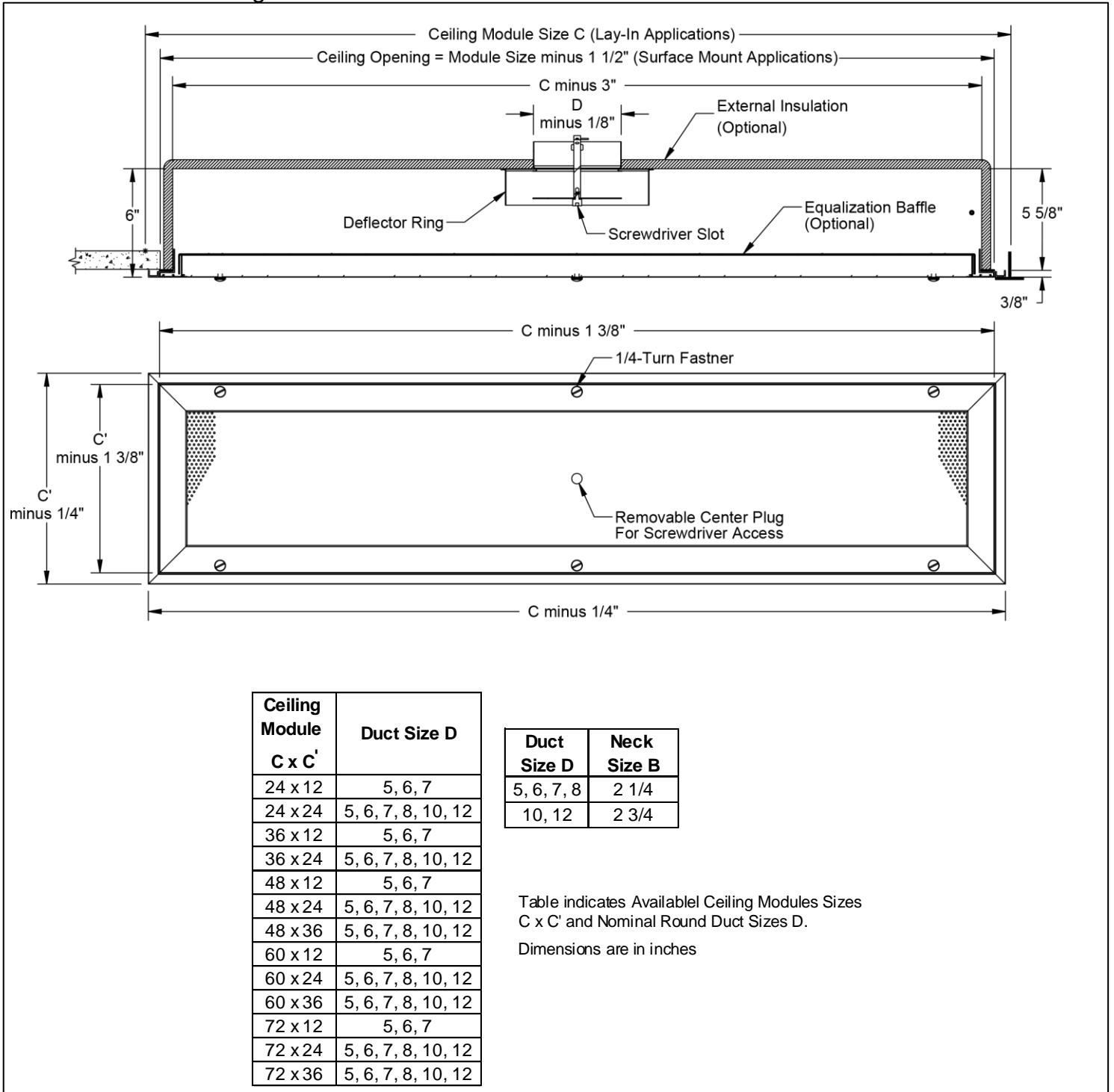
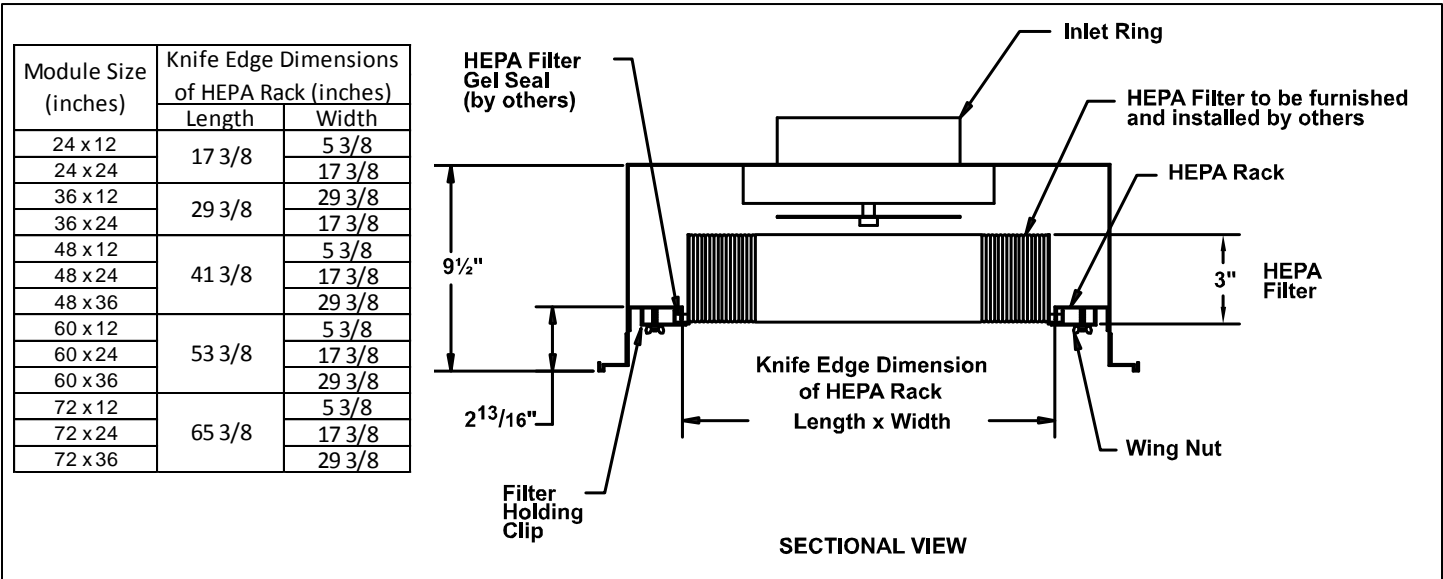

HEPA Filter Rack:

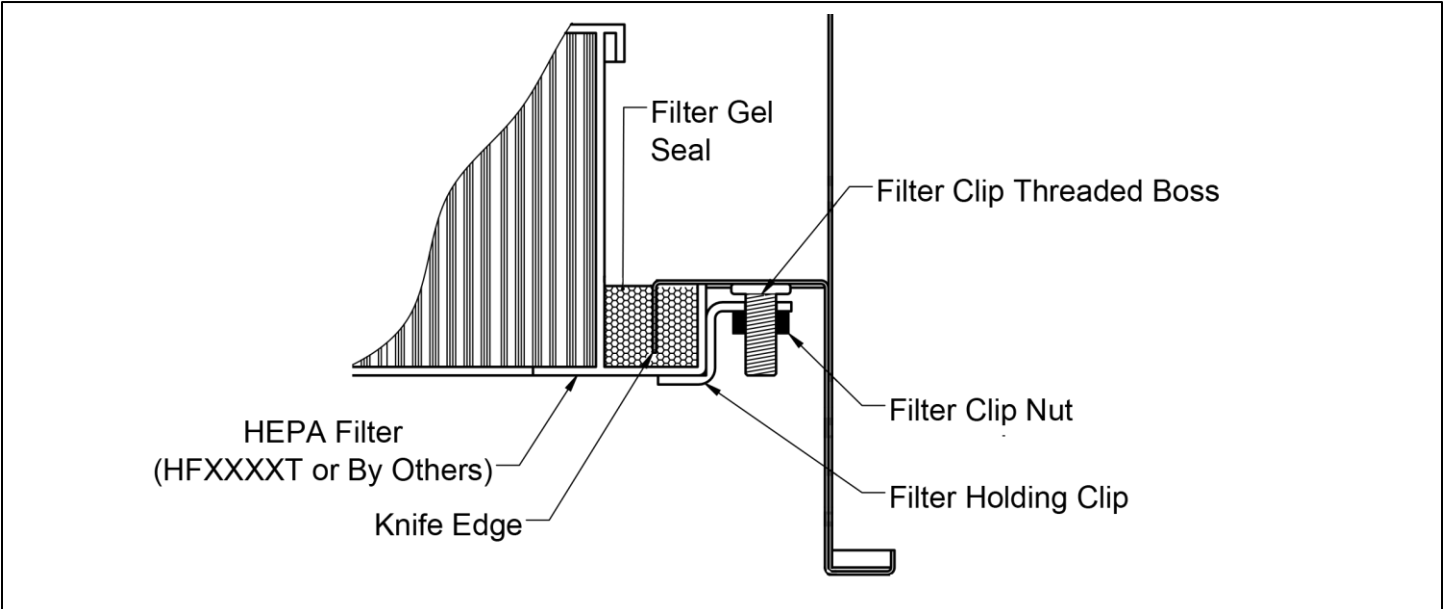

General Description

- Model TLF-AA laminar flow diffuser generates a low velocity, evenly distributed, downward moving “piston” of conditioned air.
- Installed over the operating table in a hospital operating room, Model TLF-AA helps to protect the patient from contaminated air. The only appreciable amount of room air entrainment occurs at the boundaries of the moving air mass outside the confines of the operating table. As a result, the patient is effectively isolated from residual room air.
- Model TLF-AA is especially effective in cooling areas with heavy, localized, internal loads, as in the computer room. The column of air delivered by the Model TLF-AA cools the load source directly without generating high velocities in the occupied space.
- Trim disc within perforated deflector ring allows minor equalization adjustment and is accessed by removing center plug.
- Perforated face is quickly removed by loosening ¼ turn fasteners.
- Retainer cables prevent accidental dropping of perforated face after removal.
- Internal baffles distribute air evenly over perforated face.
- 13% free area perforated face has 3/32” diameter holes on ¼” centers on 60° staggered pattern.
- Can be surfaced mounted (left side of drawing above) or laid into conventional T-bar ceiling system (right side of drawing above).
- Compatible with 1” or 1½” T-bar ceiling grids.
- Optional HEPA filter rack available (HFXXXXT or by others).

This submittal is meant to demonstrate general dimensions of this product. The drawings are not meant to detail every aspect of the product. Drawings are not to scale.

Titus reserves the right to make changes without written notice.

All rights reserved. No part of this work may be reproduced or transmitted in any form or by any means, electronic or mechanical, including photocopying and recording, or by any information storage retrieval system without permission in writing from Air Distribution Technologies.